



Model Number

CCB10-30GS55-N1-V1

Features

- 10 mm flush
- The switching distance can be set over a wide range with the potentiometer

Accessories

BF 30
Mounting flange, 30 mm

Technical Data

General specifications

Switching function	Normally open (NO)
Output type	NAMUR
Rated operating distance	s_n 10 mm
Installation	flush

Nominal ratings

Installation conditions	
A	0 mm
B	0 mm
C	20 mm
F	60 mm
Nominal voltage	U_o 8.2 V (R_i approx. 1 k Ω)
Operating voltage	U_B 5 ... 15 V
Switching frequency	f 0 ... 50 Hz
Reverse polarity protection	reverse polarity protected
Current consumption	
Measuring plate not detected	≤ 1.5 mA
Measuring plate detected	≥ 2.5 mA
Switching state indicator	LED, yellow

Ambient conditions

Ambient temperature	-20 ... 70 °C (-4 ... 158 °F)
---------------------	-------------------------------

Mechanical specifications

Connection type	Connector M12 x 1, 4-pin
Housing material	Stainless steel 1.4305 / AISI 303
Sensing face	PTFE
Degree of protection	IP67

General information

Use in the hazardous area	see instruction manuals
Category	1G; 1D

Compliance with standards and directives

Standard conformity	
NAMUR	EN 60947-5-6:2000 IEC 60947-5-6:1999
Standards	EN 60947-5-2:2007 IEC 60947-5-2:2007

Approvals and certificates

ETL approval	cETLus
CCC approval	CCC approval / marking not required for products rated ≤ 36 V

Dimensions

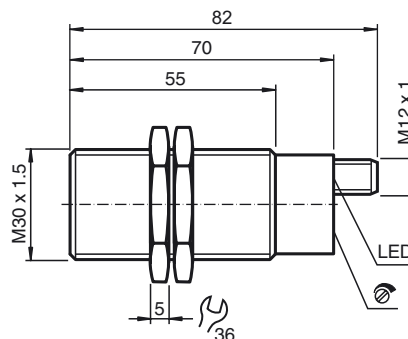

Electrical Connection

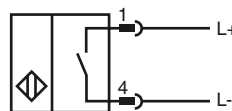

Pinout

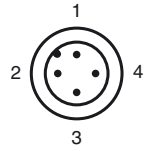

Installation Conditions

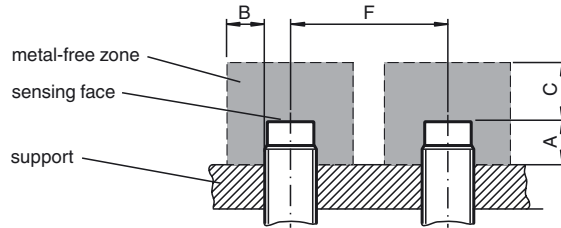

Equipment protection level Ga

Instruction

Device category 1G

EC-Type Examination Certificate

CE marking

ATEX marking

Standards

Appropriate type

Effective internal inductivity C_i Effective internal inductance L_i

General

Highest permissible ambient temperature

T6 when $P_i = 100$ mW, $U_i = 15$ V, $I_i = 30$ mAT5 when $P_i = 100$ mW, $U_i = 15$ V, $I_i = 30$ mAT4 when $P_i = 100$ mW, $U_i = 15$ V, $I_i = 30$ mAT3, T2, T1 when $P_i = 100$ mW, $U_i = 15$ V, $I_i = 30$ mA

Installation, commissioning

Maintenance

Special conditions

Electrostatic charge

Manual electrical apparatus for hazardous areas

for use in hazardous areas with gas, vapour and mist

BVS 13 ATEX E 074 X

CE 0102

II 1G Ex ia IIC T1-T6 Ga

EN 60079-0:2012, EN 60079-11:2012, EN 60079-26:2007

Ignition protection "Intrinsic safety"

CCB10-30GS55-N1...

 ≤ 250 nF ≤ 200 μ H

The apparatus has to be operated according to the appropriate data in the data sheet and in this instruction manual.

The EU-type examination certificate has to be observed. The special conditions must be adhered to!

The ATEX directive generally applies only to the use of electrical apparatus under atmospheric conditions. When using the apparatus outside atmospheric conditions, a reduction in the permissible ignition energy must be taken into account where appropriate.

40 °C (104 °F)

40 °C (104 °F)

80 °C (176 °F)

100 °C (212 °F)

Laws and/or regulations and standards governing the use or intended usage goal must be observed.

The intrinsic safety is only assured in connection with an appropriate related apparatus and according to the proof of intrinsic safety.

The associated apparatus must satisfy the requirements of category ia.

Due to the possible danger of ignition, which can arise due to faults and/or transient currents in the equipotential bonding system, galvanic isolation of the power supply and signal circuit is preferable. Associated apparatus without electrical isolation must only be used if the appropriate requirements of IEC 60079-14 are met.

No changes can be made to apparatus, which are operated in hazardous areas. Repairs to these apparatus are not possible.

Electrostatic charges must be avoided on the mechanical housing components. Dangerous electrostatic charges on the mechanical housing components can be avoided by incorporating these in the equipotential bonding.

Equipment protection level Da

Instruction

Device category 1D

EC-Type Examination Certificate

CE marking

ATEX marking

Standards

Appropriate type

Effective internal inductivity C_i Effective internal inductance L_i

General

Permissible ambient temperature range

Installation, commissioning

Maintenance

Special conditions

Electrostatic charge

Manual electrical apparatus for hazardous areas

for use in hazardous areas with combustible dust

BVS 13 ATEX E 074 X

CE 0102

II 1D Ex ia IIIC T101°C Da

EN 60079-0:2012; EN 60079-11:2012
type of protection intrinsic safety "ia"

CCB10-30GS55-N1...

 ≤ 250 nF ≤ 200 μ H

The apparatus has to be operated according to the appropriate data in the data sheet and in this instruction manual.

The EU-type examination certificate has to be observed.

The special conditions must be adhered to!

-20 ... 90 °C (-4 ... 194 °F)

Laws and/or regulations and standards governing the use or intended usage goal must be observed.

The intrinsic safety is only assured in connection with an appropriate related apparatus and according to the proof of intrinsic safety.

If the apparatus is placed entirely in Zone 20, the supply cable is introduced via a cable duct positioned close by in Zone 20 or 21.

No changes can be made to apparatus, which are operated in hazardous areas.

Repairs to these apparatus are not possible.

EN 50281-1-2 requirements, including those relating to dust deposits and temperatures, must be met.

Electrostatic charges must be avoided on the mechanical housing components.

Dangerous electrostatic charges on the mechanical housing components can be avoided by incorporating these in the equipotential bonding.

If the apparatus is placed entirely in Zone 20, the supply cable must be protected against electrostatic charge using a metal braid or pipe woven into the equipotential bonding.